

## Model 637 Cue Tone Instruction Sheet



### Description

Digital Alert Systems Model 637 Tone Decoder allows switch control via Cue Tones®.

Settings may be enabled for use of 1 to 4 Cue Tones. The output may be made to latch, toggle or provide a momentary pulse. Input levels may vary from -24 to +6 dB of audio.

Please refer to the instruction manual for the 3185E for specific switch and control settings.

### Installation

1. Remove the four screws on the cover of the 637. Refer to the model 3185E manual, and set the jumpers for latching, toggling or momentary, and the number of digits to decode. Then set the 3 rotary switches to the code to be decoded.

2. Connect the device(s) to be controlled, to the common (COMM) and the normal open (NO) or the normally closed (NC) – as desired – connections on the terminal block.
3. The connections on the terminal block for (RELAY 1) and (RELAY 2) are separate contacts, but are part of the same relay.
4. The (SET) and (RESET) connections are used as described in the 3185E manual.
5. "AudioLo and AudioHi allow connections of the audio containing the DTMF tones to be decoded. They may be balanced or unbalanced, and 600 ohm impedance or high impedance. Refer to the 3185E manual for jumper settings".
6. Connect the power supply's white wire to the +12 V DC on the 637, and the BLACK wire to (GND).
7. Replace the board in the case, and reinsert the screws to secure the case top.

### Specifications

#### Auto Input Impedance

Selectable  $600\Omega \pm 10\%$   
>10 K $\Omega$  balanced/unbalanced

#### Audio Input Coupling

AC

#### Audio Input Level

45 mV p~p (-34 dBmV) to 13.8 V p~p (+16 dBmV)

#### Audio Input Range

-24 dBmV to 6 dBmV: adjustable  
 $\pm 10$  dBmV

#### Digit Validation Time

40 mSec minimum

#### Inter-digit Time

40 mSec to 3 Sec

#### Set/Reset Inputs

>20  $\mu$ Sec to 3 Sec

#### Relay Output

DPDT; 2A @ 30 VDC

#### Power Requirement

100-240VAC, 50-60 HZ input/  
12VDC output supplied.

## **WARRANTY**

Digital Alert Systems, Inc. warrants to the owners, each instrument and sub-assembly manufactured by them to be free from defects in material and workmanship for a period of two years after shipment from factory. This warranty is applicable to the original purchaser only.

Liability under this warranty is limited to service, adjustment or replacement of defective parts (other than fuses and batteries) on any instrument or sub-assembly returned to the factory for this purpose, transportation charges prepaid.

This warranty does not apply to instruments or sub-assemblies subjected to abuse, abnormal operating conditions, or unauthorized repair or modification.

Since Digital Alert Systems, Inc. has no control over conditions of use, no warranty is made, or implied as to the suitability of our product for the customer's intended use.

THE WARRANTY SET FORTH IN THIS ARTICLE IS EXCLUSIVE AND IN LIEU OF ALL OTHER WARRANTIES AND REPRESENTATIONS, EXPRESS, IMPLIED OR STATUTORY INCLUDING, BUT NOT LIMITED TO THE IMPLIED WARRANTIES OF MERCHANTABILITY AND FITNESS. Except for obligations expressly undertaken by Digital Alert Systems, in this warranty, Owner hereby waives and releases all rights, claims and remedies with respect to any and all warranties, express, implied or statutory (including without limitation, the implied warranties of merchantability and fitness), and including but without being limited to any obligation of Digital Alert Systems with respect to incidental or consequential damages, or damages for loss of use. No agreement or understanding varying or extending the warranty will be binding upon Digital Alert Systems unless in writing signed by a duly authorized representative of Digital Alert Systems.

In the event of a breach of the foregoing warranty, the liability of Digital Alert Systems shall be limited to repairing or replacing the non-conforming goods and/or defective work, and in accordance with the foregoing, Digital Alert Systems shall not be liable for any other damages, either direct or consequential.

## **RETURN POLICY TO FACTORY**

Materials returned to Digital Alert Systems must have a Return Material Authorization number. To obtain a RMA number, contact our A/V Switching & Control Customer Service at 585-765-2254 or fax 585-765-9330. Customers have 30 days to determine that the product ordered fills their need and performs as described in the applicable literature. Units returned for approved repair or credit, must be in the original packaging including all parts and paperwork plus be in very good physical condition. If not, the customer is billed the cost to refurbish the unit and for missing accessories and merchandise. No products may be returned for change or credit after 12 months of the shipment date. Digital Alert Systems reserves the right to repair or replace units under warranty.



**Model 3185E**  
**DUAL TONE DECODER**  
**INSTRUCTION MANUAL**

Digital Alert Systems  
100 House I Ave | Lyndonville | NY | 14098 phone 585-765-2254 | fax  
585-765-9330 [digitalalertsystems.com](http://digitalalertsystems.com)

Printed in USA | Copyright© | Digital Alert Systems, Inc.  
Specifications subject to change without notice

P/N 1340163  
Version 1.20 03252019

## TABLE OF CONTENTS

DESCRIPTION	5
SPECIFICATIONS	6
INSTALLATION	7
Mounting	7
Pin Numbers and Functions	7
Figure 1 – Edge Connector, Switch and Indicator Locations	8
Figure 2 – Block Diagram	8
Audio Input Connection	9
'Set' Input Connection	9
'Reset' Input Connection	9
Relay Output Connection	9
Power Supply Input	9
CUSTOMER OPTIONS	10
FIGURE 3 – Jumper Locations	11
Input Impedance	12
Input Balanced/Unbalanced	12
5 Minute Restoral	12
Momentary Output for ON and OFF	12
Output Relay	12
10 Second Pulse	12
Number of Digits to Decode	13
Fourth Digit ON/OFF	13
CODE SELECTION	14
OPERATION	14
Operating With a 4-Digit Code	14
Operating With a 3-Digit Code	15
Operating With a 2-Digit Code	15
Operating With a 1-Digit Code	15
ADJUSTMENT	15
WARRANTY AND RETURNS	16

## DESCRIPTION

The Model 3185E Dual Tone Decoder is capable of accepting a sequence of up to four dual tone signal inputs such as those from a Touch-Tone® telephone keypad. It provides a relay closure as its output. Standard features include:

- Dual Form C Relay Output
- Selectable Input Impedance
- Selectable Balanced/Unbalanced Input
- Adjustable Input Signal Range
- Restoral of Output Status if Power Interruption is Less Than 5 Minutes.
- Selectable Momentary Output for ON and OFF sequences
- Digit Sequence Selectable up to Four Digits
- Selectable Relay Output Action (latching, momentary, or alternate).
- Level Sensitive 'Reset' Input
- Level Sensitive 'Set' Input

## SPECIFICATIONS

Input Coupling -----AC

Input Impedance:  
Factory Setting -----10 k $\Omega$  Minimum  
Selectable -----600 $\Omega$  Terminated

Input:  
Factory Setting -----Unbalanced  
Selectable -----Balanced Common Mode

Range ----- $\pm 5$  Volts

Input Signal Range:  
Minimum -----50 mV p-p  
Maximum -----1.5 V p-p

Input Range:  
Nominal -----14 dBm to -4 dBm  
(155mV to 489 mV)  
Optional ----- $\pm 10$  dBm Adjustable Digit

Validation Time -----40 ms Minimum

Inter-Digit Time:  
Minimum -----40 ms  
Maximum -----3 Seconds

Maximum Digits Per Second:  
No Twist -----13  
 $\pm 6$  dB -----12

Relay Output -----DPDT 30 VDC @ 2 Amp.

'Reset' Line -----Level Sensitive  
Minimum 20 ms Pulse to  
Ground.

'Set' Line -----Level Sensitive  
Minimum 20 ms Pulse to  
Ground.

Edge Connector ----- Model 3000RK  
(Cinch Jones 50-20A-30)

Power Requirements -----12 Volts D.C.  $\pm 10\%$   
40 mA Maximum.

Physical Dimensions -----5.0 in.H x 3.0 in.W x 0.6 in.D

## INSTALLATION

### Mounting:

The Model 3185E is designed to plug into a Model 3000RK 20-pin edge connector. All connections are intended to be made at the edge connector and will be referred to in this manual by edge connector number or letter.

### Pin Numbers and Functions:

Pin numbers are listed below for the Model 3185E when plugged into a 3000RK Connector. Consult FIGURE 1 on page 4 for proper registration of pin numbers.

PIN NUMBER	FUNCTION
1	Common terminal for relay output referenced to pins 9 and 10.
2	Circuit common (ground).
3	Circuit common (ground).
5	Audio input low (audio input circuit common if unbalanced).
6	Audio input high.
8	+12 Volt D.C. power supply input.
9	Normally closed contact for relay output referenced to pins 1 and 10.
10	Normally open contact for relay output referenced to pins 1 and 9.
A	Common terminal for relay output referenced to pins K and L.
B	Reserved. Connections to this pin will disable card.
D	'Set' input.
E	'Reset' input.
K	Normally closed contact for relay output referenced to pins A and L.
L	Normally open contact for relay output referenced to pins A and K.

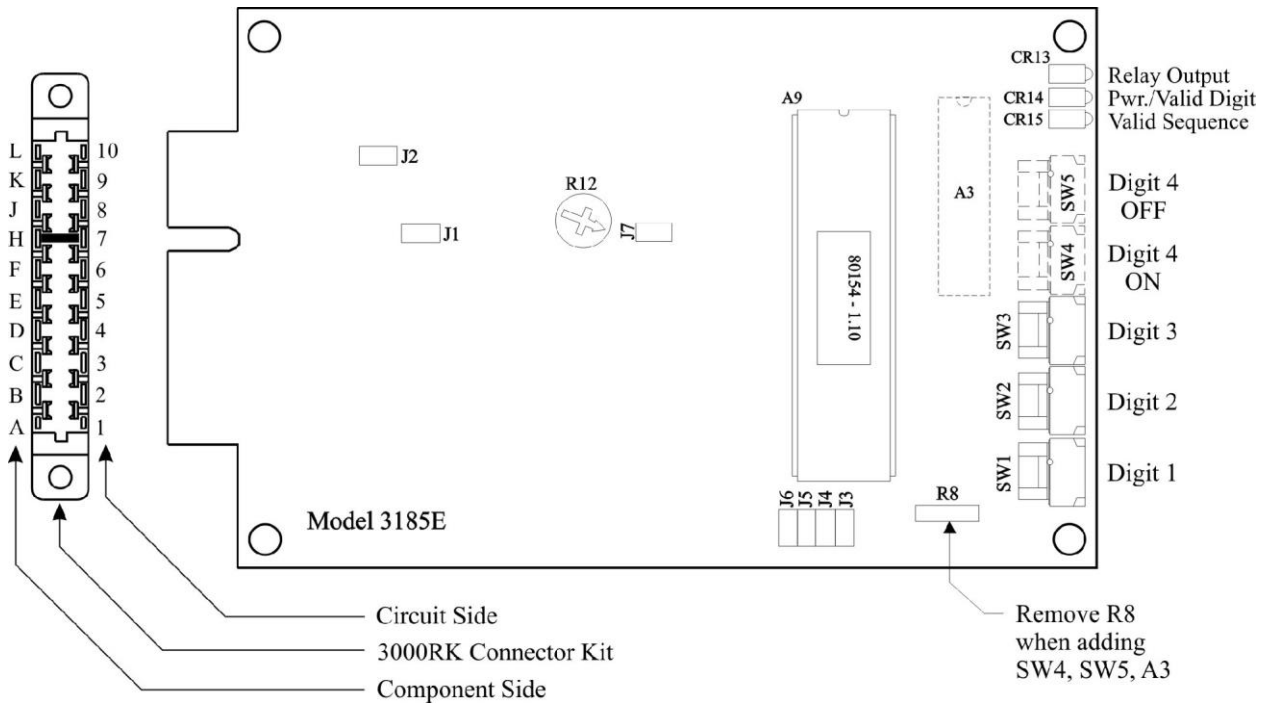

**FIGURE 1** Edge Connector, Switch and Indicator Locations and Modifications for 4 digit ON/OFF Operation

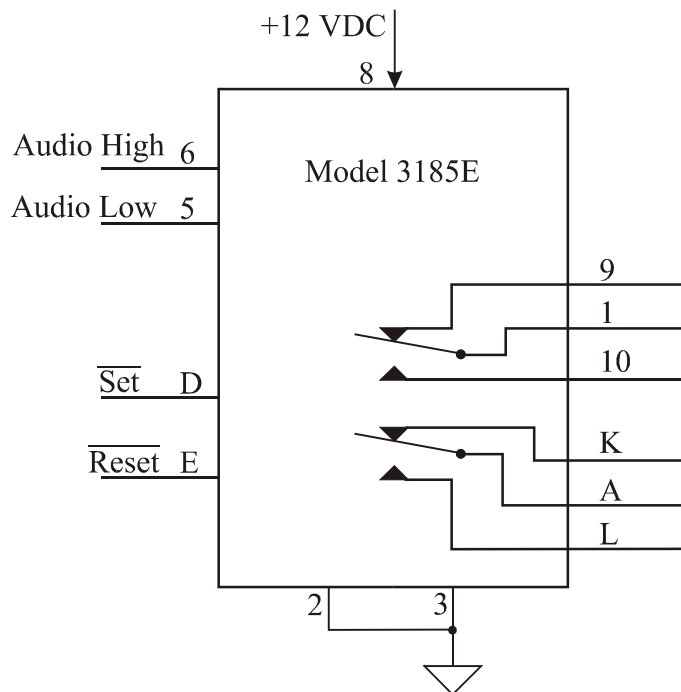

**FIGURE 2** Block Diagram



### **Audio Input Connection:**

The audio input is connected at pins '6' and '5' (circuit common). The 3185E is factory set at 10 k $\Omega$  input impedance; unbalanced. This audio input may be changed by the customer to have a 600  $\Omega$  termination instead of 10 k $\Omega$ , and also to be balanced instead of unbalanced. Consult the CUSTOMER OPTION section for more explanation.

### **'Set' Input Connection:**

The 'Set' input is connected at pin 'D', and when pulsed to circuit common will energize the output relay. The output relay will remain energized until the proper 'OFF' code is received or the 'Reset' input is pulsed to ground. This input is level sensitive and requires a minimum pulse width of 20 msec. to circuit common to activate or de-activate the output relay. The 'Set' input has precedence over all functions except 'Reset'.

If the 3185E's 'Set' input is pulsed to circuit common while decoding a code sequence it will clear previous valid digit(s) decoded after the 'Set' input returns to a 'high' state.

### **'Reset' Input Connection:**

Momentarily connecting pin 'E' to circuit common will cause the 3185E to reset. This input is level sensitive and requires a minimum pulse of 20 msec. to circuit common to reset the card. The 'Reset' input dominates over all other functions.

**NOTE:** The 3185E will ignore all commands or code sequences until the 'Reset' input is removed from circuit common.

### **Relay Output Connections:**

The 3185E provides a dual Form C relay output. The output relay will energize whenever the preprogrammed 'ON' code sequence is received or the 'Set' input is momentarily connected to circuit common. If the output relay is set to 'momentary', the output relay will activate approximately 40ms after the last valid digit is received and stay on as long as the last valid digit is present. If the output relay is set to 'latching', the output relay will remain energized until the programmed 'OFF' code sequence is received or the 'Reset' input is momentarily connected to circuit common.

The dual Form C relay output connections are shown below:

RELAY OUTPUT	COMMON CONTACT	NORMALLY CLOSED CONTACT	NORMALLY OPEN CONTACT
1 FORM C	1	9	10
1 FORM C	A	K	L

**TABLE 1**

### **Power Supply Input:**

The power supply input is connected to pins '8' (+12 VDC) and '3' (circuit common). The 3185E requires a power supply capable of providing 50mA minimum, and regulation of the +12 volt,  $\pm 10\%$ .

## CUSTOMER OPTIONS

The Model 3185E is factory set to the following:

Input Impedance:	10 k $\Omega$
Input:	Unbalanced
5 Minute Restoral:	Enabled
Momentary Output for ON and OFF:	Disabled
Output Relay:	Latching
4 Digit Decode Sequence	
* for Fourth Digit 'ON'	
# for Fourth Digit 'OFF'	

Jumpers are used to modify these options.

See FIGURE 3 on the next page.

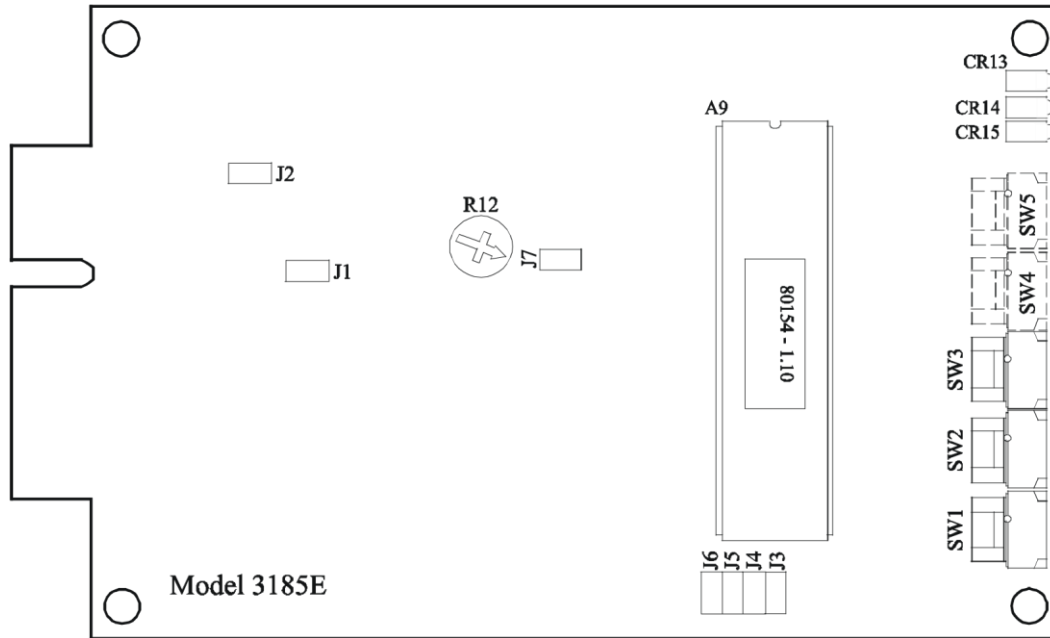

NUMBER OF DIGITS	J6	J5
1	X	X
2	X	O
3	O	X
4	O	O

RELAY OUTPUT MODE	J3	J4
LATCHING	O	O
MOMENTARY	X	O
ALTERNATE	O	X
MOMENTARY OUTPUT FOR BOTH ON & OFF	X	X

X = JUMPER INSTALLED O = JUMPER REMOVED

R12 = INPUT SIGNAL LEVEL RANGE ADJUSTMENT

	JUMPER	OPEN	SHORTED
INPUT IMPEDANCE	J2	10kΩ <sup>▪</sup>	600Ω
INPUT TERMINATION	J1	BALANCED	UNBALANCED <sup>▪</sup>
5 MINUTE RESTORAL	J7	ENABLED <sup>▪</sup>	DISABLED
MOMENTARY OUTPUT FOR BOTH ON & OFF	J3, J4	DISABLED <sup>▪</sup>	ENABLED

<sup>▪</sup> = FACTORY SETTING

FIGURE 3 Jumper Locations

### **Input Impedance:**

Input impedance may be either 10 k $\Omega$  or 600  $\Omega$ . The **J2** jumper determines the input impedance of the 3185E. Install a jumper at position **J2** to terminate the audio input in 600  $\Omega$ . Consult FIGURE 3 for the **J2** jumper location.

### **Input Balanced/Unbalanced:**

The input may be selected to be balanced or unbalanced. The **J1** jumper determines whether the input is balanced or unbalanced. Removing the short from **J1** will make the input balanced. Consult FIGURE 3 for the **J1** jumper location.

### **5 Minute Restoral:**

The 3185E may be selected to restore the output status for a power interruption of less than five minutes. The 3185E is factory set to enable this restoral. The **J7** jumper is open. To disable the five minute restoral install a jumper on **J7**. Consult FIGURE 3 for **J7** location.

### **Momentary Output for ON & OFF:**

This setting provides a momentary output relay activation for both the ON sequence and the OFF sequence. Momentary duration is 1 second. To enable this feature, install both J3 and J4.

### **Output Relay:**

The output relay on the 3185E may be set in three different modes of operation; *latching*, *momentary* or *alternate action* (toggling). The 3185E is factory set to latching.

Being set at *latching* means the output relay will energize when the pre-programmed 'ON' code is received or the 'Set' input is momentarily connected to circuit common. The output relay will remain energized until the preprogrammed 'OFF' code is received or the 'Reset' input is momentarily connected to circuit common.

When the output relay is programmed to operate in the *momentary* mode, it will energize for the duration that the last valid digit is present. In the momentary mode the 3185E will not respond to its pre-programmed 'OFF' code.

*Alternate action* programs the relay for latching (toggling) relay output. In this mode the output relay energizes and de-energizes with the same pre-programmed 'ON' code sequence.

### **10 Second Pulse:**

If both 'Set' and 'Reset' are low and the relay mode is 'momentary', then when a valid 'ON' sequence of digits is received, the relay is turned on for 10 seconds then 'OFF' – even if the last tone is still present. The decoder will ignore all tones and 'Set' and 'Reset' activities during the 10-second period. Applies only to firmware version 80154-1.10 and later.

The programming of jumpers for the output relay is shown below. Consult FIGURE 3 page 7 for the 'J3' jumper and the 'J4' jumper location.

RELAY OUTPUT MODE	JUMPER	
	J3	J4
LATCHING	O	O
MOMENTARY	X	O
ALTERNATE	O	X
MOMENTARY OUTPUT FOR BOTH ON & OFF	X	X

**TABLE 2**

X = JUMPER INSTALLED  
O = JUMPER REMOVED

**Number of Digits to Decode:**

The 3185E is factory set to decode a 4-digit 'ON' code sequence and a 4-digit 'OFF' code sequence. The first three digits of the code sequence are the same for both 'ON' and 'OFF'. The fourth digit for the 'ON' code sequence is factory set to '\*', and the fourth digit for the 'OFF' code sequence is factory set to '#'. The number of digits to decode is determined by jumpers 'J6' and 'J5'. Consult FIGURE 3 page 7 for the location of 'J6' and 'J5'.

The programming of jumpers for the number of digits to decode is shown below:

NUMBER OF DIGITS	JUMPER	
	J6	J5
1	X	X
2	X	O
3	O	X
4	O	O

**TABLE 3**

X = JUMPER INSTALLED  
O = JUMPER REMOVED

**Fourth Digit ON/OFF:**

The fourth digit of the 'ON' code sequence and the fourth digit of the 'OFF' code sequence are factory set at '\*' and '#' respectively. To enable user selection of the fourth digits, it is necessary to remove resistor 'R8' and install two additional selection switches, S4 and S5, plus IC A3. When ordering the switches, please use Digital Alert Systems part number '9200002' for each of the two switches and part number '9120375' for the IC required.

Consult the PC board layout in Figure 1, on Page 4, for the location of the parts to be removed and inserted.

## CODE SELECTION

The hexadecimal rotary switches on the front edge of the 3185E determine each digit in the code sequence. 0 through D select the corresponding DTMF digit to be decoded. The letter 'E' on the rotary switch represents the '\*' DTMF digit and the letter 'F' on the rotary switch represents the '#' DTMF digit.

As stated before, the 3185E is factory set to decode a 4-digit 'ON' code sequence and a 4-digit 'OFF' code sequence. The first three digits of the code sequence are the same for 'ON' and 'OFF' commands. The fourth digit for the 'ON' code sequence is factory set to '\*', and the fourth digit for the 'OFF' code sequence is factory set to '#'.

It is not necessary to power down the 3185E when you are programming the code sequence. The 3185E program will read the switch settings each time a code sequence is received.

Consult FIGURE 1 on page 4 for location of switches and their designations.

## OPERATION

When the 3185E is connected to a DC power source, the Power/Valid Digit LED CR14 on the front edge of the PC board will be illuminated. This LED indicator will continue to illuminate until a valid DTMF digit is detected or DC power is removed from the board.

The Valid Sequence LED CR15 will illuminate upon the decoding of a correct DTMF code tone pair in the proper sequence. Upon the fourth correct digit, the output relay activates and the Relay Output LED CR13 illuminates.

During the reception of valid DTMF tone pairs in a sequence the 3185E will — after decoding a valid code number — wait for the next valid code in the sequence. If the time between digits is more than 3 seconds, the 3185E will reset and require that the sequence be sent completely again.

### Operating With a 4-Digit Code:

When a 4-digit code sequence is selected on the 3185E the switch program will be as follows:

**SWITCH 1** = first digit of the code sequence for both 'ON' and 'OFF'.

**SWITCH 2** = second digit of the code sequence for both 'ON' and 'OFF'.

**SWITCH 3** = third digit of the code sequence for both 'ON' and 'OFF'.

**SWITCH 4** = fourth digit of the code sequence for 'ON' (preset to '\*' if switch not installed).

**SWITCH 5** = fourth digit of the code sequence for 'OFF' (preset to '#' if switch not installed).

If the 3185E is programmed for momentary relay output or alternating relay action SWITCH 5 is not used for programming.

### **Operating With a 3-Digit Code:**

When a 3-digit code sequence is selected on the 3185E the switch program will be as follows:

**SWITCH 1** = first digit of code sequence for both 'ON' and 'OFF'.

**SWITCH 2** = second digit of code sequence for both 'ON' and 'OFF'.

**SWITCH 3** = third digit of code sequence for 'ON'.

**SWITCH 4** = third digit of code sequence for 'OFF' (preset to '\*' if switch not installed).

If the 3185E is programmed for momentary relay output or alternating relay action SWITCH 4 is not used for programming.

### **Operating With a 2-Digit Code:**

When a 2-digit code sequence is selected on the 3185E the switch program will be as follows:

**SWITCH 1** = first digit of code sequence for both 'ON' and 'OFF'.

**SWITCH 2** = second digit of code sequence for 'ON'.

**SWITCH 3** = second digit for code sequence for 'OFF'.

If the 3185E is programmed for momentary relay output or alternating relay action SWITCH 3 is not used for programming.

### **Operating With a 1-Digit Code:**

When a 1-digit code sequence is programmed into the 3185E the switch program is as follows:

**SWITCH 1** = first digit of code sequence for 'ON'.

**SWITCH 2** = first digit of code sequence for 'OFF'.

If the 3185E is programmed for momentary relay output or alternating relay action SWITCH 2 is not used for programming.

## **ADJUSTMENT**

Potentiometer **R12** permits the user to adjust the level of the received DTMF tones. This adjustment would be made when the received audio levels are too low or too high to permit reliable decoding. Setting **R12** fully counterclockwise will provide -10 dBmV of gain. Setting **R12** fully clockwise will provide +10 dBmV of gain.

Consult FIGURE 3 on page 7 for the location of potentiometer **R12**.

## **WARRANTY**

Digital Alert Systems, Inc. warrants to the owners, each instrument and sub-assembly manufactured by them to be free from defects in material and workmanship for a period of two years after shipment from factory. This warranty is applicable to the original purchaser only.

Liability under this warranty is limited to service, adjustment or replacement of defective parts (other than fuses and batteries) on any instrument or sub-assembly returned to the factory for this purpose, transportation charges prepaid.

This warranty does not apply to instruments or sub-assemblies subjected to abuse, abnormal operating conditions, or unauthorized repair or modification.

Since Digital Alert Systems, Inc. has no control over conditions of use, no warranty is made, or implied as to the suitability of our product for the customer's intended use.

THE WARRANTY SET FORTH IN THIS ARTICLE IS EXCLUSIVE AND IN LIEU OF ALL OTHER WARRANTIES AND REPRESENTATIONS, EXPRESS, IMPLIED OR STATUTORY INCLUDING, BUT NOT LIMITED TO THE IMPLIED WARRANTIES OF MERCHANTABILITY AND FITNESS. Except for obligations expressly undertaken by Digital Alert Systems, in this warranty, Owner hereby waives and releases all rights, claims and remedies with respect to any and all warranties, express, implied or statutory (including without limitation, the implied warranties of merchantability and fitness), and including but without being limited to any obligation of Digital Alert Systems with respect to incidental or consequential damages, or damages for loss of use. No agreement or understanding varying or extending the warranty will be binding upon Digital Alert Systems unless in writing signed by a duly authorized representative of Digital Alert Systems.

In the event of a breach of the foregoing warranty, the liability of Digital Alert Systems shall be limited to repairing or replacing the non-conforming goods and/or defective work, and in accordance with the foregoing, Digital Alert Systems shall not be liable for any other damages, either direct or consequential.

## **RETURN POLICY TO FACTORY**

Materials returned to Digital Alert Systems must have a Return Material Authorization number. To obtain a RMA number, contact our A/V Switching & Control Customer Service at 585-765-2254 or fax 585-765-9330. Customers have 30 days to determine that the product ordered fills their need and performs as described in the applicable literature. Units returned for approved repair or credit, must be in the original packaging including all parts and paperwork plus be in very good physical condition. If not, the customer is billed the cost to refurbish the unit and for missing accessories and merchandise. No products may be returned for exchange or credit after 12 months of the shipment date. Digital Alert Systems reserves the right to repair or replace units under warranty.