



Series 3000 Model R-103A

**DUAL TONE SENDER
INSTRUCTION MANUAL**

Digital Alert Systems
100 Housel Ave | Lyndonville | NY | 14098
585-765-2254 | fax 585-765-9330
digitalalertsystems.com

Printed in USA | Copyright© | Digital Alert Systems, Inc.
Specifications subject to change without notice

P/N 1340165
06052019

TABLE OF CONTENTS

TABLE OF CONTENTS	PAGE 2
WARRANTY/ RETURN POLICY	PAGE 3
SPECIFICATIONS	PAGE 4
DESCRIPTION	PAGE 5
INSTALLATION	PAGE 6
OPERATION	PAGE 8
ADJUSTMENTS	PAGE 9
RACK – FRONT VIEW	PAGE 10
3185E MANUAL	

WARRANTY

Digital Alert Systems, Inc. warrants to the owners, each instrument and sub-assembly manufactured by them to be free from defects in material and workmanship for a period of two years after shipment from factory. This warranty is applicable to the original purchaser only.

Liability under this warranty is limited to service, adjustment or replacement of defective parts (other than fuses and batteries) on any instrument or sub-assembly returned to the factory for this purpose, transportation charges prepaid.

This warranty does not apply to instruments or sub-assemblies subjected to abuse, abnormal operating conditions, or unauthorized repair or modification.

Since Digital Alert Systems, Inc. has no control over conditions of use, no warranty is made, or implied as to the suitability of our product for the customer's intended use.

THE WARRANTY SET FORTH IN THIS ARTICLE IS EXCLUSIVE AND IN LIEU OF ALL OTHER WARRANTIES AND REPRESENTATIONS, EXPRESS, IMPLIED OR STATUTORY INCLUDING, BUT NOT LIMITED TO THE IMPLIED WARRANTIES OF MERCHANTABILITY AND FITNESS. Except for obligations expressly undertaken by Digital Alert Systems, in this warranty, Owner hereby waives and releases all rights, claims and remedies with respect to any and all warranties, express, implied or statutory (including without limitation, the implied warranties of merchantability and fitness), and including but without being limited to any obligation of Digital Alert Systems with respect to incidental or consequential damages, or damages for loss of use. No agreement or understanding varying or extending the warranty will be binding upon Digital Alert Systems unless in writing signed by a duly authorized representative of Digital Alert Systems.

In the event of a breach of the foregoing warranty, the liability of Digital Alert Systems shall be limited to repairing or replacing the non-conforming goods and/or defective work, and in accordance with the foregoing, Digital Alert Systems shall not be liable for any other damages, either direct or consequential.

RETURN POLICY TO FACTORY

Materials returned to Digital Alert Systems must have a Return Material Authorization number. To obtain a RMA number, contact our A/V Switching & Control Customer Service at 585-765-2254 or fax 585-765-9330. Customers have 30 days to determine that the product ordered fills their need and performs as described in the applicable literature. Units returned for approved repair or credit, must be in the original packaging including all parts and paperwork plus be in very good physical condition. If not, the customer is billed the cost to refurbish the unit and for missing accessories and merchandise. No products may be returned for change or credit after 12 months of the shipment date. Digital Alert Systems reserves the right to repair or replace units under warranty.

SPECIFICATIONS

Number of Cue Tone Sequences:

1 set of On/Off standard,
2 to 4 optional

Output Impedance:

600 Ω , balanced

Cue Tone Output Level:

Adjustable, 2 mV to 2 V RMS

Cue Tone Delay Time:

Adjustable, 0.25 to 1.75 Sec.

Cue Tone Transmission Rate:

Adjustable, 5 to 200 digits/Sec.

Second Cue Tone Automatic

Re-send Timing:

Adjustable, over a wide range

Power Requirements:

94 - 240 VAC, $\pm 10\%$, 50/60 Hz
UL/CSA/CD power supply

Physical:

3.5" H X 9.5" D X 19" W

Weight: 5 lbs.

DESCRIPTION

The model 3000R-103A Dual Tone Sender is a preprogrammed CATV Cue Tone generator designed to place DTMF (Touch-Tone*) cues on CATV program audio. The cue tones are transmitted to provide CATV systems with unattended switching and can signal beginning and ending of:

- Daily Programming
- Program Segments
- Local Announcements or Commercials

The model 3000R-103A can provide up to eight Cue Tone codes; four ON and four OFF.

Internal Cue Tone Decoders monitor program audio and provide verification that the cues have been properly transmitted.

Front panel pushbutton switches and indicators permit operation; rear panel terminals allow external switches and indicators to be added if desired.

*Touch-Tone is a registered trademark of AT&T

INSTALLATION

Three terminal strips are provided on the rear panel of the model R103A for external connections.

PROGRAM AUDIO CONNECTION:

Cue Tones can be inserted on the same carrier as the program audio or inserted on their own carrier. If they are to be inserted on the program audio carrier, it is necessary to ensure that no program audio is present while cue tones are being transmitted. Therefore, the program audio should be routed through the normally closed contacts of the 3000R-103A's balanced audio relay.

- A. Open the program audio line and connect the audio source across TB1, terminals 11 and 12.
- B. Take the audio output from TB2, terminals 11 and 12.

NOTE: In the event of power or equipment failure the 3000R-103A will not interrupt the program audio.

If the Cue Tones will be inserted on their own audio carrier, make the connection in step B above.

MONITOR AUDIO CONNECTION:

Program monitor audio must be wired to TB3, terminals 11 and 12 to provide verification that the cue tones have been properly transmitted. To accomplish this, jumper TB2 terminals 11 and 12 to TB3 terminals 11 and 12.

If program monitor audio is not available, TB3 terminals 11 and 12 may be wired directly to the program audio source if desired. The monitor audio input is transformer coupled (600 ohms) to the internal decoders.

REMOTE SWITCH CONNECTIONS:

Barrier strip TB1, terminals 1 through 9 provide connections for installation of remote switches to activate cue tone codes.

Momentary pushbutton switches can be wired from any or all terminals 1 through 8, to terminal 9. Momentarily grounding any terminal 1 through 8 will cause the 3000R-103A to transmit the code controlled by that input.

TB1 TERMINAL	CODE
1	1 ON
2	1 OFF
3	2 ON
4	2 OFF
5	3 ON
6	3 OFF
7	4 ON
8	4 OFF
9 COMMON (GROUND)	

REMOTE INDICATOR CONNECTION:

Barrier strip TB2 terminals 1 through 9 provide connections for installation of remote indicators controlled by the internal Cue Tone Decoders.

Any type of LED indicators with proper current limiting resistors can be used for remote indicators.

TB2 TERMINAL	CODE
1	1 ON (GREEN)
2	1 OFF (RED)
3	2 ON (GREEN)
4	2 OFF (RED)
5	3 ON (GREEN)
6	3 OFF (RED)
7	4 ON (GREEN)
8	4 OFF (RED)
9	+5VDC OUTPUT

OPERATION

When the Model R103A is first plugged into a 117 VAC outlet the front panel red indicator lamps will be "ON" for each channel that is installed.

Pressing the front panel ON switch for any active channel will cause the R103A to send its preprogrammed Cue Tone out on TB2, terminals 11 and 12. When equipped with 3223B-2 transmission begins when switch is pushed.

ADJUSTMENTS

All adjustments are made with respect to barrier strip TB2, terminals 11 and 12.

CUE TONE LEVEL:

A screwdriver adjustment in the center of the rear panel is provided for adjustment of the Cue Tone level into the program audio. Maximum audio level is obtained by turning this control fully clockwise.

The Cue Tone level on the program audio should be adjusted for – 12 dBm (200 MV RMS). The Model 3171B (A4 position) has an on board level adjustment R10. By placing the rear panel level adjustment in its center position the model 3171B R10 can be adjusted counterclockwise to decrease the Cue Tone level to the desired level.

CUE TONE DELAY:

The delay time between a switch closure and the beginning of a Cue Tone transmission may also be adjusted. The Model 3223B-2 (A5 position channel 1 and 2) and or (A2 position channel 3 and 4) has an on board adjustment R12. Turning R12 clockwise will lengthen delay time between a switch closure and the beginning of a Cue Tone transmission, this factory set at a one second delay.

CUE TONE TRANSMISSION RATE:

The Cue Tone transmission rate may be adjusted for other than the factory setting of 10 Hz (50 ms first pulse width). The Model 3223B-2 (A5 position channel 1 and 2) and/or (A2 position channel 3 and 4) has an on board adjustment R11. Turning R11 clockwise will increase the transmission rate; 12.5 Hz. Equals 40 ms first pulse width; 14.3 Hz. Equals 35 ms first pulse width.

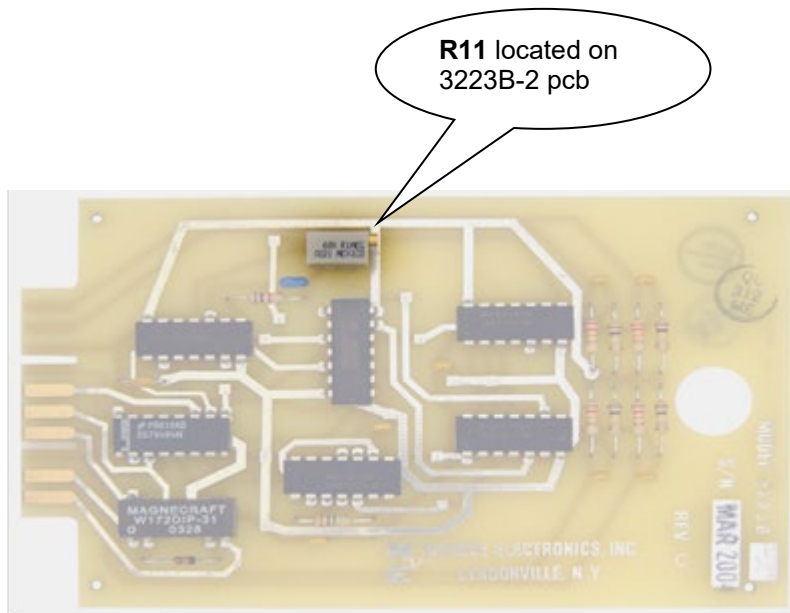

Front View – R103A
(with cover removed)

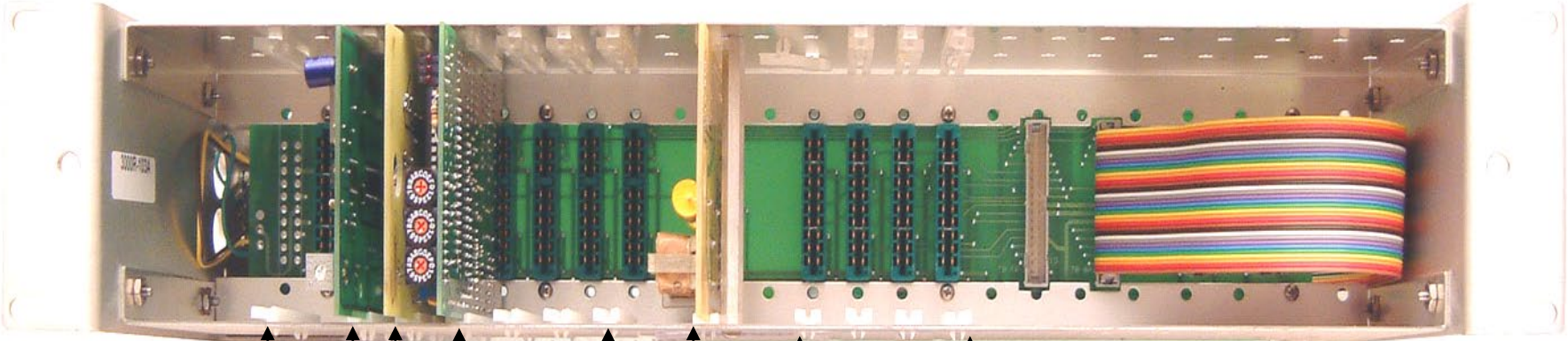

3223B Controller
(up to 2)

3171B Encoder

3185E Decoders
(up to 4)

3191 Coupler

Not used on R103A

Model 3185E
DUAL TONE DECODER
INSTRUCTION MANUAL

Digital Alert Systems
100 House I Ave | Lyndonville | NY | 14098 phone 585-765-
2254 | fax 585-765-9330 digitalalertsystems.com

Printed in USA | Copyright© | Digital Alert Systems, Inc.
Specifications subject to change without notice

P/N 1340163
Version 1.21 03252019

TABLE OF CONTENTS

DESCRIPTION-----	3
SPECIFICATIONS-----	4
INSTALLATION -----	5
Mounting -----	5
Pin Numbers and Functions -----	5
FIGURE 1 - <i>Edge Connector, Switch and Indicator Locations</i> -----	6
FIGURE 2 - <i>Block Diagram</i> -----	6
Audio Input Connection -----	7
‘Set’ Input Connection -----	7
“Reset” Input Connection-----	7
Relay Output Connection -----	7
Power Supply Input -----	7
CUSTOMER OPTIONS -----	8
FIGURE 3 - <i>Jumper Locations</i> -----	8
Input Impedance -----	9
Input Balanced/Unbalanced -----	9
5 Minute Restoral -----	10
Momentary Output for ON and OFF -----	10
Output Relay -----	10
10 Second Pulse-----	10
Number of Digits to Decode -----	11
Fourth Digit ON/OFF -----	11
CODE SELECTION -----	11
OPERATION -----	12
Operating With a 4-Digit Code -----	12
Operating With a 3-Digit Code -----	12
Operating With a 2-Digit Code -----	13
Operating With a 1-Digit Code -----	13
ADJUSTMENT -----	13
RETURN TO FACTORY POLICY-----	13
WARRANTY -----	14

DESCRIPTION

The Model 3185E Dual Tone Decoder is capable of accepting a sequence of up to four dual tone signal inputs such as those from a Touch-Tone® telephone keypad. It provides a relay closure as its output. Standard features include:

- Dual Form C Relay Output
- Selectable Input Impedance
- Selectable Balanced/Unbalanced Input
- Adjustable Input Signal Range
- Restoral of Output Status if Power Interruption is Less Than 5 Minutes.
- Selectable Momentary Output for ON and OFF sequences
- Digit Sequence Selectable up to Four Digits
- Selectable Relay Output Action (latching, momentary, or alternate).
- Level Sensitive 'Reset' Input
- Level Sensitive 'Set' Input

SPECIFICATIONS

Input Coupling -----	AC
Input Impedance:	
Factory Setting -----	10 k Ω Minimum
Selectable -----	600 Ω Terminated
Input:	
Factory Setting -----	Unbalanced
Selectable-----	Balanced Common
Mode Range -----	\pm 5 Volts
Input Signal Range:	
Minimum -----	50 mV p-p
Maximum -----	1.5 V p-p
Input Range:	
Nominal -----	14 dBm to -4 dBm (155mV to 489 mV)
Optional -----	\pm 10 dBm Adjustable Digit
Validation Time -----	40 ms Minimum
Inter-Digit Time:	
Minimum -----	40 ms
Maximum -----	3 Seconds
Maximum Digits Per Second:	
No Twist -----	13
\pm 6 dB -----	12
Relay Output -----	DPDT 30 VDC @ 2 Amp.
'Reset' Line -----	Level Sensitive Minimum 20 ms Pulse to Ground.
'Set' Line -----	Level Sensitive Minimum 20 ms Pulse to Ground.
Edge Connector -----	Model 3000RK (Cinch Jones 50-20A-30)
Power Requirements -----	12 Volts D.C. \pm 10% 40 mA Maximum.
Physical Dimensions -----	5.0 in.H x 3.0 in.W x 0.6 in.D

INSTALLATION

Mounting:

The Model 3185E is designed to plug into a Model 3000RK 20-pin edge connector. All connections are intended to be made at the edge connector and will be referred to in this manual by edge connector number or letter.

Pin Numbers and Functions:

Pin numbers are listed below for the Model 3185E when plugged into a 3000RK Connector. Consult FIGURE 1 on page 4 for proper registration of pin numbers.

PIN NUMBER	FUNCTION
1	Common terminal for relay output referenced to pins 9 and 10.
2	Circuit common (ground).
3	Circuit common (ground).
5	Audio input low (audio input circuit common if unbalanced).
6	Audio input high.
8	+12 Volt D.C. power supply input.
9	Normally closed contact for relay output referenced to pins 1 and 10.
10	Normally open contact for relay output referenced to pins 1 and 9.
A	Common terminal for relay output referenced to pins K and L.
B	Reserved. Connections to this pin will disable card.
D	'Set' input.
E	'Reset' input.
K	Normally closed contact for relay output referenced to pins A and L.
L	Normally open contact for relay output referenced to pins A and K.

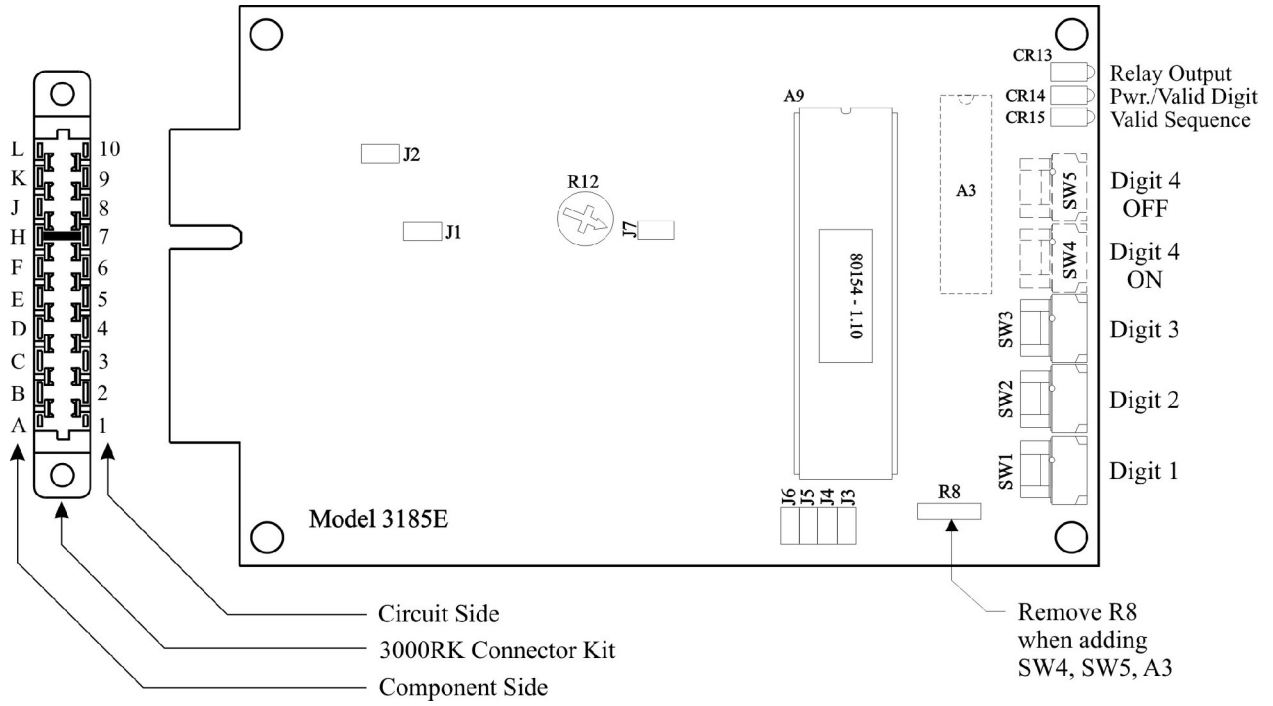

FIGURE 1 Edge Connector, Switch and Indicator Locations and Modifications for 4 digit ON/OFF Operation

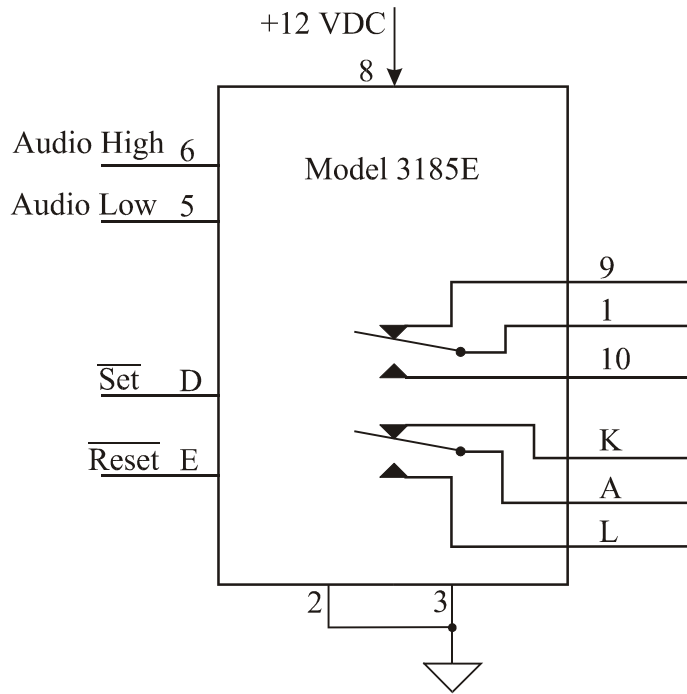

FIGURE 2 Block Diagram

Audio Input Connection:

The audio input is connected at pins '6' and '5' (circuit common). The 3185E is factory set at 10 k Ω input impedance; unbalanced. This audio input may be changed by the customer to have a 600 Ω termination instead of 10 k Ω , and also to be balanced instead of unbalanced. Consult the CUSTOMER OPTION section for more explanation.

'Set' Input Connection:

The 'Set' input is connected at pin 'D', and when pulsed to circuit common will energize the output relay. The output relay will remain energized until the proper 'OFF' code is received or the 'Reset' input is pulsed to ground. This input is level sensitive and requires a minimum pulse width of 20 msec. to circuit common to activate or de-activate the output relay. The 'Set' input has precedence over all functions except 'Reset'.

If the 3185E's 'Set' input is pulsed to circuit common while decoding a code sequence it will clear previous valid digit(s) decoded after the 'Set' input returns to a 'high' state.

'Reset' Input Connection:

Momentarily connecting pin 'E' to circuit common will cause the 3185E to reset. This input is level sensitive and requires a minimum pulse of 20 msec. to circuit common to reset the card. The 'Reset' input dominates over all other functions.

NOTE: The 3185E will ignore all commands or code sequences until the 'Reset' input is removed from circuit common.

Relay Output Connections:

The 3185E provides a dual Form C relay output. The output relay will energize whenever the preprogrammed 'ON' code sequence is received or the 'Set' input is momentarily connected to circuit common. If the output relay is set to 'momentary', the output relay will activate approximately 40ms after the last valid digit is received and stay on as long as the last valid digit is present. If the output relay is set to 'latching', the output relay will remain energized until the programmed 'OFF' code sequence is received or the 'Reset' input is momentarily connected to circuit common.

The dual Form C relay output connections are shown below:

RELAY OUTPUT	COMMON CONTACT	NORMALLY CLOSED CONTACT	NORMALLY OPEN CONTACT
1 FORM C	1	9	10
1 FORM C	A	K	L

TABLE 1

Power Supply Input:

The power supply input is connected to pins '8' (+12 VDC) and '3' (circuit common). The 3185E requires a power supply capable of providing 50mA minimum, and regulation of the +12 volt, $\pm 10\%$.

CUSTOMER OPTIONS

The Model 3185E is factory set to the following:

- Input Impedance: 10 k Ω
- Input: Unbalanced
- 5 Minute Restoral: Enabled
- Momentary Output for ON and OFF: Disabled
- Output Relay: Latching
- 4 Digit Decode Sequence
- * for Fourt Digit 'ON'
- # for Fourth Digit 'OFF'

Jumpers are used to modify these options. See FIGURE 3.

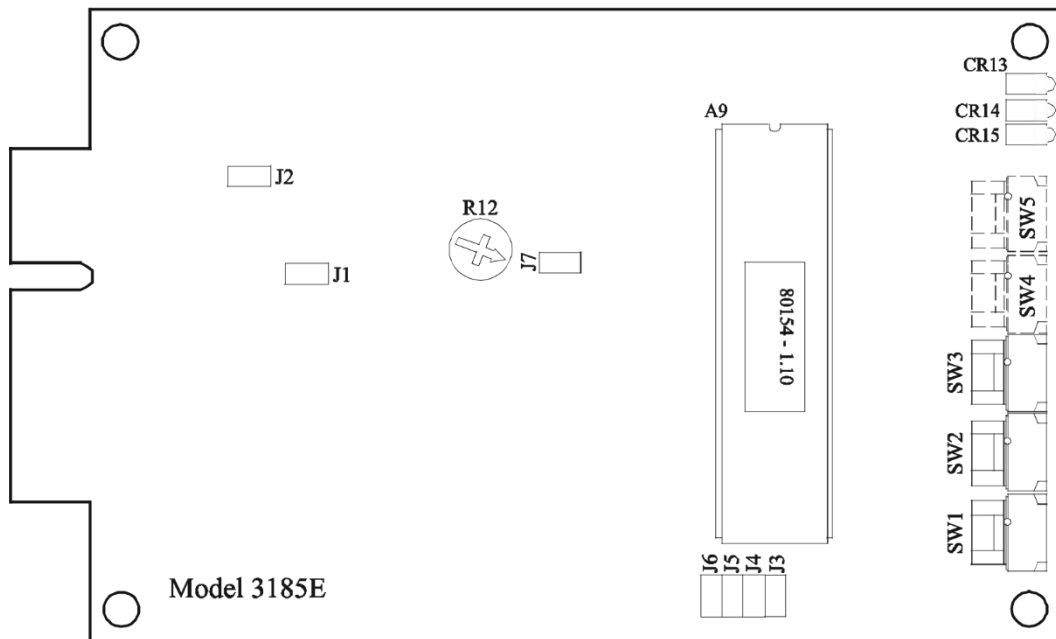

NUMBER OF DIGITS	J6	J5
1	X	X
2	X	O
3	O	X
4	O	O

RELAY OUTPUT MODE	J3	J4
LATCHING	O	O
MOMENTARY	X	O
ALTERNATE	O	X
MOMENTARY OUTPUT FOR BOTH ON & OFF	X	X

X = JUMPER INSTALLED
O = JUMPER REMOVED

R12 = INPUT SIGNAL LEVEL RANGE ADJUSTMENT

	JUMPER	OPEN	SHORTED
INPUT IMPEDANCE	J2	10kΩ [▪]	600Ω
INPUT TERMINATION	J1	BALANCED	UNBALANCED [▪]
5 MINUTE RESTORAL	J7	ENABLED [▪]	DISABLED
MOMENTARY OUTPUT FOR BOTH ON & OFF	J3, J4	DISABLED [▪]	ENABLED

[▪] = FACTORY SETTING
FIGURE 3 Jumper Locations

Input Impedance:

Input impedance may be either 10 kΩ or 600 Ω. The **J2** jumper determines the input impedance of the 3185E. Install a jumper at position **J2** to terminate the audio input in 600 Ω. Consult FIGURE 3 for the **J2** jumper location.

Input Balanced/Unbalanced:

The input may be selected to be balanced or unbalanced. The **J1** jumper determines whether the input is balanced or unbalanced. Removing the short from **J1** will make the input balanced. Consult FIGURE 3 for the **J1** jumper location.

5 Minute Restoral:

The 3185E may be selected to restore the output status for a power interruption of less than five minutes. The 3185E is factory set to enable this restoral. The **J7** jumper is open. To disable the five minute restoral install a jumper on **J7**. Consult FIGURE 3 for **J7** location.

Momentary Output for ON & OFF:

This setting provides a momentary output relay activation for both the ON sequence and the OFF sequence. Momentary duration is 1 second. To enable this feature, install both J3 and J4.

Output Relay:

The output relay on the 3185E may be set in three different modes of operation; *latching*, *momentary* or *alternate action* (toggling). The 3185E is factory set to latching.

Being set at *latching* means the output relay will energize when the pre-programmed 'ON' code is received or the 'Set' input is momentarily connected to circuit common. The output relay will remain energized until the preprogrammed 'OFF' code is received or the 'Reset' input is momentarily connected to circuit common.

When the output relay is programmed to operate in the *momentary* mode, it will energize for the duration that the last valid digit is present. In the momentary mode the 3185E will not respond to its pre-programmed 'OFF' code.

Alternate action programs the relay for latching (toggling) relay output. In this mode the output relay energizes and de-energizes with the same pre-programmed 'ON' code sequence.

10 Second Pulse:

If both 'Set' and 'Reset' are low and the relay mode is 'momentary', then when a valid 'ON' sequence of digits is received, the relay is turned on for 10 seconds then 'OFF' – even if the last tone is still present. The decoder will ignore all tones and 'Set' and 'Reset' activities during the 10-second period. Applies only to firmware version 80154-1.10 and later.

The programming of jumpers for the output relay is shown below. Consult FIGURE 3 page 7 for the '**J3**' jumper and the '**J4**' jumper location.

RELAY OUTPUT MODE	JUMPER	
	J3	J4
LATCHING	O	O
MOMENTARY	X	O
ALTERNATE	O	X
MOMENTARY OUTPUT FOR BOTH ON & OFF	X	X

TABLE 2

X = JUMPER INSTALLED
O = JUMPER REMOVED

Number of Digits to Decode:

The 3185E is factory set to decode a 4-digit 'ON' code sequence and a 4-digit 'OFF' code sequence. The first three digits of the code sequence are the same for both 'ON' and 'OFF'. The fourth digit for the 'ON' code sequence is factory set to '*', and the fourth digit for the 'OFF' code sequence is factory set to '#'. The number of digits to decode is determined by jumpers 'J6' and 'J5'. Consult FIGURE 3 page 7 for the location of 'J6' and 'J5'.

The programming of jumpers for the number of digits to decode is shown below:

NUMBER OF DIGITS	JUMPER	
	J6	J5
1	X	X
2	X	O
3	O	X
4	O	O

TABLE 3

X = JUMPER INSTALLED

O = JUMPER REMOVED

Fourth Digit ON/OFF:

The fourth digit of the 'ON' code sequence and the fourth digit of the 'OFF' code sequence are factory set at '*' and '#' respectively. To enable user selection of the fourth digits, it is necessary to remove resistor 'R8' and install two additional selection switches, S4 and S5, plus IC A3. When ordering the switches, please use Digital Alert Systems part number '9200002' for each of the two switches and part number '9120375' for the IC required.

Consult the PC board layout in Figure 1, on Page 4, for the location of the parts to be removed and inserted.

CODE SELECTION

The hexadecimal rotary switches on the front edge of the 3185E determine each digit in the code sequence. 0 through D select the corresponding DTMF digit to be decoded. The letter 'E' on the rotary switch represents the '*' DTMF digit and the letter 'F' on the rotary switch represents the '#' DTMF digit.

As stated before, the 3185E is factory set to decode a 4-digit 'ON' code sequence and a 4-digit 'OFF' code sequence. The first three digits of the code sequence are the same for 'ON' and 'OFF' commands. The fourth digit for the 'ON' code sequence is factory set to '*', and the fourth digit for the 'OFF' code sequence is factory set to '#'.

It is not necessary to power down the 3185E when you are programming the code sequence. The 3185E program will read the switch settings each time a code sequence is received.

Consult FIGURE 1 on page 4 for location of switches and their designations.

OPERATION

When the 3185E is connected to a DC power source, the Power/Valid Digit LED CR14 on the front edge of the PC board will be illuminated. This LED indicator will continue to illuminate until a valid DTMF digit is detected or DC power is removed from the board.

The Valid Sequence LED CR15 will illuminate upon the decoding of a correct DTMF code tone pair in the proper sequence. Upon the fourth correct digit, the output relay activates and the Relay Output LED CR13 illuminates.

During the reception of valid DTMF tone pairs in a sequence the 3185E will — after decoding a valid code number — wait for the next valid code in the sequence. If the time between digits is more than 3 seconds, the 3185E will reset and require that the sequence be sent completely again.

Operating With a 4-Digit Code:

When a 4-digit code sequence is selected on the 3185E the switch program will be as follows:

SWITCH 1 = first digit of the code sequence for both 'ON' and 'OFF'.

SWITCH 2 = second digit of the code sequence for both 'ON' and 'OFF'.

SWITCH 3 = third digit of the code sequence for both 'ON' and 'OFF'.

SWITCH 4 = fourth digit of the code sequence for 'ON' (preset to '*' if switch not installed).

SWITCH 5 = fourth digit of the code sequence for 'OFF' (preset to '#' if switch not installed).

If the 3185E is programmed for momentary relay output or alternating relay action SWITCH 5 is not used for programming.

Operating With a 3-Digit Code:

When a 3-digit code sequence is selected on the 3185E the switch program will be as follows:

SWITCH 1 = first digit of code sequence for both 'ON' and 'OFF'.

SWITCH 2 = second digit of code sequence for both 'ON' and 'OFF'.

SWITCH 3 = third digit of code sequence for 'ON'.

SWITCH 4 = third digit of code sequence for 'OFF' (preset to '*' if switch not installed).

If the 3185E is programmed for momentary relay output or alternating relay action SWITCH 4 is not used for programming.

Operating With a 2-Digit Code:

When a 2-digit code sequence is selected on the 3185E the switch program will be as follows:

SWITCH 1 = first digit of code sequence for both 'ON' and 'OFF'.

SWITCH 2 = second digit of code sequence for 'ON'.

SWITCH 3 = second digit for code sequence for 'OFF'.

If the 3185E is programmed for momentary relay output or alternating relay action SWITCH 3 is not used for programming.

Operating With a 1-Digit Code:

When a 1-digit code sequence is programmed into the 3185E the switch program is as follows:

SWITCH 1 = first digit of code sequence for 'ON'.

SWITCH 2 = first digit of code sequence for 'OFF'.

If the 3185E is programmed for momentary relay output or alternating relay action SWITCH 2 is not used for programming.

ADJUSTMENT

Potentiometer **R12** permits the user to adjust the level of the received DTMF tones. This adjustment would be made when the received audio levels are too low or too high to permit reliable decoding. Setting **R12** fully counterclockwise will provide -10 dBmV of gain. Setting **R12** fully clockwise will provide +10 dBmV of gain.

Consult FIGURE 3 on page 7 for the location of potentiometer **R12**.

WARRANTY

Digital Alert Systems, Inc. warrants to the owners, each instrument and sub-assembly manufactured by them to be free from defects in material and workmanship for a period of two years after shipment from factory. This warranty is applicable to the original purchaser only.

Liability under this warranty is limited to service, adjustment or replacement of defective parts (other than fuses and batteries) on any instrument or sub-assembly returned to the factory for this purpose, transportation charges prepaid.

This warranty does not apply to instruments or sub-assemblies subjected to abuse, abnormal operating conditions, or unauthorized repair or modification.

Since Digital Alert Systems, Inc. has no control over conditions of use, no warranty is made, or implied as to the suitability of our product for the customer's intended use.

THE WARRANTY SET FORTH IN THIS ARTICLE IS EXCLUSIVE AND IN LIEU OF ALL OTHER WARRANTIES AND REPRESENTATIONS, EXPRESS, IMPLIED OR STATUTORY INCLUDING, BUT NOT LIMITED TO THE IMPLIED WARRANTIES OF MERCHANTABILITY AND FITNESS. Except for obligations expressly undertaken by Digital Alert Systems, in this warranty, Owner hereby waives and releases all rights, claims and remedies with respect to any and all warranties, express, implied or statutory (including without limitation, the implied warranties of merchantability and fitness), and including but without being limited to any obligation of Digital Alert Systems with respect to incidental or consequential damages, or damages for loss of use. No agreement or understanding varying or extending the warranty will be binding upon Digital Alert Systems unless in writing signed by a duly authorized representative of Digital Alert Systems.

In the event of a breach of the foregoing warranty, the liability of Digital Alert Systems shall be limited to repairing or replacing the non-conforming goods and/or defective work, and in accordance with the foregoing, Digital Alert Systems shall not be liable for any other damages, either direct or consequential.

RETURN POLICY TO FACTORY

Materials returned to Digital Alert Systems must have a Return Material Authorization number. To obtain a RMA number, contact our A/V Switching & Control Customer Service at 585-765-2254 or fax 585-765-9330. Customers have 30 days to determine that the product ordered fills their need and performs as described in the applicable literature. Units returned for approved repair or credit, must be in the original packaging including all parts and paperwork plus be in very good physical condition. If not, the customer is billed the cost to refurbish the unit and for missing accessories and merchandise. No products may be returned for exchange or credit after 12 months of the shipment date. Digital Alert Systems reserves the right to repair or replace units under warranty.